

Copeland F-Series

Scroll condensing units - 60Hz



Key features of scroll units

- Optimal layout of components, tubing and electrical connections for easy serviceability
- Energy efficient silent fans
- Condenser coils designed for high ambient conditions
 - Large condenser face area and higher CFM for elevated ambient conditions
- Liquid receiver, HP/LP switch, crankcase heater, liquid line with filter drier and sight glass as standard feature
- Pre-wired electrical junction box
- Copeland Scroll compressor
 - Proven reliability
 - Lower sound levels and pulsations
 - Dual compliance for superior efficiency and better liquid handling



Nomenclature

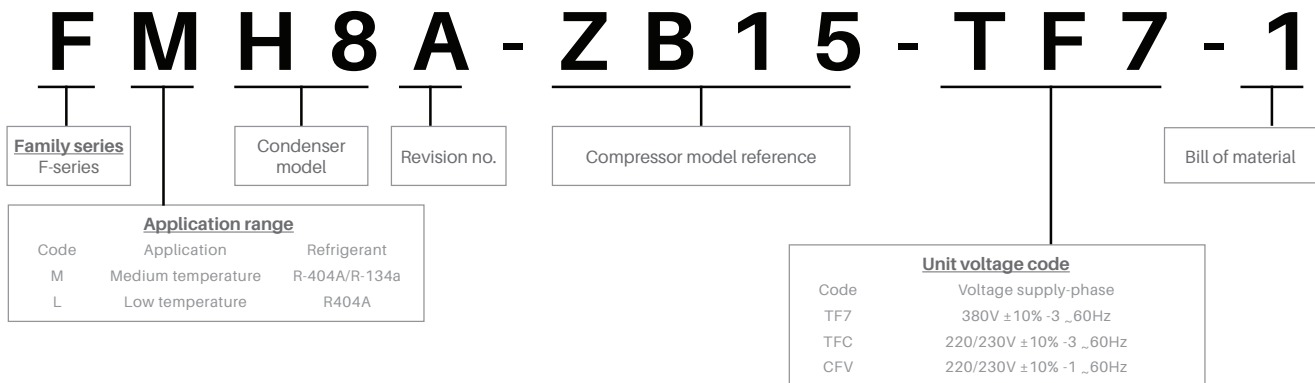

Small compressor features

Dual compliance

Compliance means sealing between the orbiting and fixed scroll involutes. Dual compliance means the sealing is on both the axial and radial directions, resulting in increased efficiency. This prevents refrigerant leak back across successive scroll pressure pockets. Compliance design also allows the scroll involutes to separate in both the radial and axial directions. This allows debris or liquid refrigerant to pass through the scroll involutes without damaging the compressor.

Scroll wear-in

The scroll involutes of Copeland Scroll compressor wear-in, rather than wear-out. So unlike in other compressor technologies among similar categories, there is no constant degradation of performance with time due to wear-out.

Lower sound, vibration and pulsation

The compression process in a scroll set is symmetrical and continuous. This inherently reduces the sound, vibration and pulsation. This eliminates the need for use of vibration absorbers and suction or discharge mufflers in most of the applications.

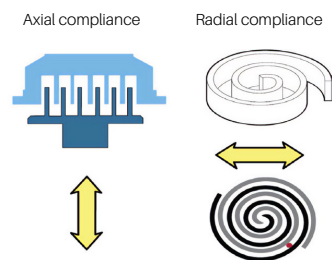

Medium temperature

Model (no. of fans)	Ambient temperature (°C)	Capacity evaporating temperature (°C)							Power evaporating temperature (°C)						
		-20	-15	-10	-5	0	5	7	-20	-15	-10	-5	0	5	7
FMH8-ZB15 1	32	2.92	3.57	4.28	5.06	5.91	6.81	7.19	2.21	2.22	2.23	2.24	2.26	2.30	2.32
	38	2.53	3.13	3.78	4.48	5.24	6.05	6.39	2.59	2.58	2.57	2.57	2.57	2.60	2.62
	43	2.18	2.74	3.33	3.97	4.66	5.39	5.69	2.98	2.96	2.93	2.90	2.89	2.90	2.91
	46	1.95	2.49	3.05	3.65	4.30	4.98	5.27	3.26	3.22	3.17	3.13	3.10	3.10	3.10
	49		2.22	2.76	3.32	3.93				3.51	3.45	3.39	3.34		
FMM8-ZB19 1	32	3.33	4.11	4.99	5.96	7.02	8.16	8.64	2.41	2.46	2.52	2.58	2.64	2.71	2.74
	38	2.97	3.68	4.48	5.36	6.32	7.36	7.79	2.69	2.75	2.80	2.87	2.93	3.00	3.03
	43	2.65	3.30	4.03	4.84	5.72	6.67	7.07	2.95	3.01	3.07	3.13	3.20	3.26	3.29
	46	2.45	3.07	3.75	4.51	5.34	6.24	6.62	3.12	3.18	3.24	3.30	3.37	3.44	3.46
	49		2.82	3.47	4.18	4.96	5.81			3.36	3.42	3.48	3.55	3.62	
FMM8-ZB21 1	32	4.34	5.20	6.18	7.26	8.43	9.66	10.16	2.98	3.07	3.16	3.24	3.34	3.45	3.50
	38	3.90	4.68	5.56	6.53	7.58	8.69	9.14	3.37	3.47	3.55	3.65	3.75	3.87	3.92
	43	3.54	4.24	5.04	5.92	6.86	7.87	8.28	3.72	3.82	3.91	4.01	4.11	4.24	4.30
	46	3.32	3.97	4.72	5.54	6.43	7.37		3.94	4.04	4.14	4.23	4.34	4.47	
	49		3.71	4.40	5.17					4.27	4.37	4.47			
FMR6-ZB26 2	32	5.15	6.23	7.44	8.77	10.20	11.75	12.40	3.41	3.50	3.61	3.71	3.83	3.94	3.98
	38	4.62	5.60	6.69	7.89	9.20	10.60	11.15	3.85	3.95	4.06	4.17	4.28	4.40	4.44
	43	4.16	5.05	6.04	7.14	8.33	9.60	10.15	4.27	4.37	4.48	4.59	4.70	4.82	4.86
	46	3.87	4.70	5.64	6.67	7.79	9.00	9.50	4.54	4.64	4.75	4.86	4.97	5.09	5.13
	49		4.35	5.22	6.19					4.93	5.04	5.14			
FMR7-ZB29 2	32	6.10	7.33	8.69	10.20	11.84	13.61	14.35	3.89	3.99	4.10	4.21	4.32	4.44	4.49
	38	5.51	6.63	7.86	9.22	10.71	12.31	12.99	4.38	4.48	4.59	4.70	4.82	4.94	4.99
	43	4.99	6.00	7.13	8.37	9.73	11.20	11.82	4.84	4.94	5.04	5.16	5.28	5.40	5.45
	46	4.66	5.62	6.68	7.85	9.13	10.52	11.11	5.14	5.23	5.34	5.45	5.57	5.69	5.74
	49		5.21	6.21	7.31					5.55	5.66	5.77			
FMS9-ZB38 2	32	7.68	9.22	10.94	12.82	14.88	17.10	18.03	4.80	4.93	5.06	5.21	5.36	5.51	5.57
	38	6.94	8.33	9.88	11.59	13.45	15.47	16.32	5.42	5.55	5.68	5.83	5.98	6.14	6.20
	43	6.27	7.55	8.97	10.52	12.22	14.07	14.85	6.00	6.12	6.26	6.41	6.56	6.72	6.78
	46	5.86	7.06	8.39	9.86	11.46	13.21	13.95	6.38	6.50	6.64	6.79	6.94	7.09	7.16
	49		6.55	7.80	9.18					6.90	7.04	7.18			
FMV9-ZB45 2	32	9.12	10.96	13.00	15.24	17.68	20.32	21.43	5.52	5.67	5.83	5.99	6.17	6.35	6.42
	38	8.24	9.90	11.75	13.78	15.99	18.39	19.40	6.24	6.39	6.55	6.72	6.90	7.08	7.15
	43	7.46	8.98	10.66	12.51	14.53	16.73	17.65	6.91	7.06	7.22	7.40	7.57	7.76	7.83
	46	6.96	8.40	9.98	11.72	13.63	15.71	16.58	7.36	7.50	7.66	7.83	8.01	8.19	8.26
	49		7.79	9.28	10.92					7.97	8.13	8.30			
FMV9-ZB48 2	32	9.92	11.89	14.08	16.47	19.07	21.87	23.04	6.12	6.30	6.49	6.69	6.90	7.11	7.20
	38	8.94	10.73	12.70	14.86	17.21	19.75	20.81	6.92	7.10	7.29	7.50	7.71	7.93	8.02
	43	8.07	9.70	11.50	13.47	15.61	17.92	18.90	7.68	7.85	8.05	8.25	8.46	8.69	8.77
	46	7.52	9.06	10.75	12.60	14.62	16.81		8.17	8.34	8.53	8.74	8.95	9.17	
	49		8.39	9.97	11.71					8.86	9.05	9.25			
FMV6-ZB57 2	32	11.85	14.20	16.80	19.70	22.90	26.30	27.70	6.76	7.16	7.56	7.96	8.35	8.74	8.89
	38	10.85	13.00	15.35	17.95	20.80	23.80	25.10	7.40	7.82	8.25	8.68	9.10	9.51	9.67
	43	10.00	11.95	14.05	16.35	18.90	21.60	22.80	8.00	8.44	8.89	9.34	9.78	10.20	10.40
	46	9.44	11.25	13.20	15.35	17.70	20.20	21.30	8.39	8.85	9.31	9.77	10.20	10.65	10.80
	49		10.50	12.35	14.30	16.45				9.27	9.74	10.20	10.65		
FMV6-ZB66 2	32	13.36	16.04	18.97	22.16	25.61	29.32	30.88	8.38	8.68	9.02	9.37	9.74	10.10	10.24
	38	12.07	14.52	17.16	20.02	23.11	26.43	27.82	9.35	9.65	9.99	10.33	10.69	11.04	11.17
	43	10.93	13.18	15.59	18.18	20.96	23.95	25.21	10.25	10.56	10.88	11.22	11.56	11.90	12.03
	46	10.20	12.34	14.61	17.03	19.64	22.44		10.84	11.14	11.47	11.80	12.13	12.45	
	49		11.47	13.60	15.86					11.77	12.08	12.41			

Note:
 1. Operating conditions: 20°C suction gas return temperature and 0K sub cooling
 2. Stated power values are inclusive of fan power

Medium temperature

Model (no. of fans)	Ambient temperature (°C)	Capacity evaporating temperature (°C)							Power evaporating temperature (°C)						
		-15	-10	-5	0	5	7	10	-15	-10	-5	0	5	7	10
FMH8-ZB15 1	32	2.08	2.70	3.32	4.04	4.86	5.21	5.77	1.28	1.31	1.34	1.37	1.41	1.43	1.46
	38	1.93	2.44	3.11	3.79	4.55	4.88	5.41	1.42	1.45	1.48	1.52	1.57	1.58	1.61
	43	1.80	2.28	2.85	3.57	4.29	4.60	5.09	1.54	1.58	1.62	1.66	1.71	1.73	1.76
	46		2.18	2.73	3.43	4.13	4.43	4.90		1.66	1.71	1.75	1.80	1.82	1.85
	49		2.09	2.61	3.22	3.96	4.25	4.71		1.76	1.80	1.85	1.90	1.92	1.95
FMM8-ZB19 1	32	2.42	3.14	3.88	4.72	5.69	6.10	6.77	1.41	1.43	1.47	1.50	1.54	1.56	1.59
	38	2.25	2.84	3.63	4.43	5.33	5.73	6.35	1.56	1.59	1.63	1.67	1.71	1.73	1.76
	43	2.10	2.66	3.33	4.18	5.03	5.40	5.99	1.71	1.74	1.78	1.83	1.87	1.89	1.92
	46	2.01	2.55	3.19	4.02	4.84	5.20	5.77	1.80	1.84	1.88	1.93	1.98	2.00	2.03
	49		2.44	3.06	3.78	4.66	5.00	5.54		1.94	1.99	2.03	2.09	2.11	2.14
FMM8-ZB21 1	32	3.02	3.91	4.82	5.86	7.03	7.54	8.34	1.71	1.75	1.80	1.85	1.91	1.94	1.98
	38	2.80	3.53	4.51	5.48	6.58	7.06	7.81	1.90	1.95	2.00	2.06	2.13	2.15	2.20
	43	2.61	3.30	4.12	5.16	6.20	6.65	7.36	2.08	2.13	2.19	2.26	2.33	2.36	2.40
	46		3.16	3.95	4.97	5.97	6.40	7.08		2.26	2.32	2.39	2.46	2.49	2.54
	49		3.02	3.78	4.66	5.73	6.14	6.80		2.39	2.45	2.52	2.60	2.63	2.68
FMR6-ZB26 2	32	3.49	4.53	5.57	6.78	8.14	8.72	9.65	1.90	1.94	1.99	2.05	2.12	2.15	2.20
	38	3.23	4.09	5.22	6.35	7.62	8.17	9.05	2.12	2.17	2.23	2.29	2.37	2.40	2.45
	43	3.02	3.82	4.77	5.98	7.18	7.70	8.52	2.32	2.38	2.44	2.52	2.60	2.63	2.68
	46		3.66	4.57	5.75	6.91	7.41	8.20		2.52	2.59	2.67	2.75	2.78	2.83
	49		3.50	4.37	5.40	6.63	7.11	7.87		2.67	2.74	2.82	2.90	2.94	2.99
FMR7-ZB29 2	32	4.08	5.26	6.46	7.83	9.40	10.08	11.18	2.39	2.44	2.50	2.56	2.63	2.66	2.71
	38	3.76	4.74	6.03	7.32	8.80	9.44	10.47	2.67	2.72	2.78	2.84	2.92	2.95	3.00
	43	3.48	4.42	5.50	6.89	8.28	8.89	9.86	2.92	2.97	3.03	3.11	3.18	3.22	3.27
	46		4.22	5.27	6.62	7.97	8.55	9.48		3.14	3.20	3.28	3.36	3.39	3.44
	49		4.02	5.04	6.21	7.65	8.21	9.10		3.32	3.38	3.45	3.54	3.57	3.63
FMS9-ZB38 2	32	5.06	6.61	8.15	9.91	11.90	12.76	14.14	2.82	2.91	2.99	3.07	3.17	3.21	3.29
	38	4.69	5.99	7.65	9.30	11.16	11.97	13.26	3.14	3.23	3.32	3.40	3.51	3.56	3.64
	43	4.38	5.61	7.01	8.78	10.53	11.30	12.51	3.45	3.53	3.62	3.72	3.83	3.88	3.96
	46		5.38	6.74	8.46	10.15	10.88	12.05		3.74	3.83	3.93	4.04	4.09	4.17
	49		5.15	6.46	7.95	9.76	10.46	11.58		3.96	4.05	4.15	4.26	4.31	4.40
FMV9-ZB45 2	32	6.13	7.93	9.80	11.94	14.33	15.36	16.97	3.19	3.27	3.36	3.46	3.57	3.61	3.68
	38	5.65	7.14	9.15	11.17	13.43	14.39	15.91	3.57	3.65	3.76	3.86	3.98	4.03	4.10
	43	5.24	6.65	8.34	10.50	12.64	13.55	14.98	3.92	4.01	4.11	4.24	4.36	4.41	4.49
	46		6.35	7.98	10.09	12.15	13.03	14.41		4.25	4.36	4.48	4.61	4.66	4.74
	49		6.04	7.62	9.45	11.65	12.50	13.82		4.51	4.61	4.73	4.87	4.93	5.01
FMV9-ZB48 2	32	6.89	8.61	10.84	13.10	15.64	16.73	18.46	3.67	3.76	3.87	3.98	4.12	4.19	4.30
	38	6.38	8.01	10.15	12.27	14.65	15.67	17.29	4.12	4.22	4.34	4.46	4.60	4.67	4.79
	43	5.94	7.49	9.28	11.56	13.80	14.76	16.28	4.56	4.66	4.77	4.91	5.06	5.13	5.25
	46		7.17	8.90	11.12	13.27	14.20	15.66		4.95	5.06	5.20	5.36	5.43	5.55
	49		6.84	8.52	10.44	12.74	13.64	15.04		5.26	5.37	5.50	5.68	5.75	5.87
FMV6-ZB57 2	32	7.53	9.84	12.15	14.85	17.90	19.20	21.30	4.26	4.47	4.67	4.86	5.03	5.09	5.18
	38	6.96	8.88	11.40	13.90	16.80	18.05	20.00	4.62	4.85	5.08	5.30	5.51	5.60	5.71
	43	6.47	8.30	10.40	13.10	15.85	17.05	18.95	4.97	5.20	5.45	5.69	5.93	6.03	6.17
	46		7.95	10.00	12.65	15.30	16.45	18.25		5.43	5.68	5.93	6.19	6.29	6.45
	49		7.59	9.57	11.90	14.70	15.80	17.60		5.67	5.93	6.19	6.46	6.57	6.74
FMV6-ZB66 2	32	8.67	11.29	13.95	17.02	20.48	21.98	24.34	5.00	5.13	5.30	5.49	5.67	5.74	5.83
	38	7.95	10.09	12.98	15.88	19.16	20.58	22.83	5.56	5.69	5.89	6.09	6.28	6.35	6.44
	43	7.35	9.36	11.78	14.90	18.02	19.37	21.52	6.07	6.22	6.41	6.64	6.84	6.91	7.00
	46		8.92	11.26	14.30	17.32	18.63	20.71		6.55	6.75	6.99	7.20	7.27	7.36
	49		8.48	10.73	13.38	16.61	17.88	19.89		6.89	7.11	7.34	7.57	7.65	7.74

Note:
 1. Operating conditions: 20°C suction gas return temperature and 0K sub cooling
 2. Stated power values are inclusive of fan power

■ 11K suction superheat

Low temperature

Model (no. of fans)	Ambient temperature (°C)	Capacity evaporating temperature (°C)							Power evaporating temperature (°C)						
		-40	-35	-30	-25	-20	-15	-10	-40	-35	-30	-25	-20	-15	-10
FLH8-ZF06 1	32	1.39	1.77	2.19	2.65	3.17	3.76	4.41	1.80	1.82	1.90	2.00	2.13	2.29	2.46
	38	1.27	1.62	2.01	2.43	2.90	3.42	4.01	2.03	2.03	2.09	2.19	2.31	2.47	2.64
	43	1.17	1.51	1.86	2.25	2.67	3.14	3.67	2.23	2.22	2.26	2.35	2.47	2.62	2.79
	46	1.12	1.44	1.78	2.15	2.54	2.98	3.47	2.35	2.33	2.36	2.44	2.56	2.70	2.87
	49	1.08	1.39	1.70	2.04	2.41	2.82	3.27	2.48	2.44	2.46	2.53	2.64	2.78	2.94
FLM8-ZF09 1	32	1.99	2.50	3.07	3.72	4.45	5.28	6.20	2.17	2.23	2.33	2.44	2.59	2.75	2.95
	38	1.84	2.30	2.83	3.41	4.07	4.81	5.64	2.41	2.47	2.56	2.67	2.81	2.98	3.17
	43	1.70	2.13	2.60	3.14	3.73	4.40	5.16	2.65	2.70	2.78	2.89	3.02	3.19	3.37
	46	1.60	2.02	2.47	2.96	3.52	4.15	4.86	2.80	2.85	2.93	3.03	3.16	3.32	3.51
	49	1.51	1.90	2.32	2.79	3.31	3.89	4.55	2.97	3.01	3.08	3.19	3.31	3.47	3.65
FLR6-ZF11 2	32	2.49	3.12	3.84	4.66	5.58	6.62	7.77	2.54	2.65	2.78	2.95	3.15	3.37	3.63
	38	2.30	2.88	3.53	4.27	5.10	6.03	7.07	2.83	2.94	3.07	3.24	3.43	3.66	3.92
	43	2.13	2.65	3.25	3.91	4.67	5.51	6.45	3.10	3.21	3.35	3.51	3.71	3.93	4.19
	46	2.01	2.51	3.06	3.69	4.39	5.18	6.06	3.28	3.39	3.52	3.69	3.89	4.11	4.37
	49	1.89	2.36	2.87	3.45	4.11	4.84	5.67	3.46	3.57	3.71	3.88	4.08	4.30	4.55
FLR7-ZF13 2	32	2.73	3.47	4.32	5.28	6.36	7.56	8.88	2.98	3.07	3.19	3.35	3.53	3.75	4.01
	38	2.53	3.18	3.93	4.80	5.77	6.87	8.08	3.29	3.39	3.51	3.66	3.85	4.07	4.32
	43	2.36	2.93	3.60	4.37	5.26	6.26	7.37	3.59	3.69	3.82	3.97	4.15	4.37	4.62
	46	2.27	2.78	3.40	4.11	4.94	5.88	6.93	3.79	3.90	4.02	4.17	4.36	4.57	4.82
	49	2.18	2.64	3.19	3.85	4.61	5.49	6.48	4.01	4.12	4.24	4.40	4.58	4.79	5.04
FLS9-ZF15 2	32	3.48	4.35	5.35	6.50	7.81	9.28	10.90	3.46	3.62	3.81	4.03	4.28	4.57	4.91
	38	3.20	4.00	4.91	5.94	7.11	8.43	9.91	3.78	3.98	4.19	4.43	4.70	5.00	5.34
	43	2.95	3.68	4.51	5.44	6.50	7.69	9.03	4.06	4.30	4.55	4.81	5.09	5.40	5.74
	46	2.80	3.48	4.26	5.13	6.11	7.23	8.48	4.24	4.51	4.77	5.05	5.35	5.67	6.01
	49	2.63	3.28	4.00	4.80	5.72	6.76	7.92	4.43	4.72	5.01	5.31	5.62	5.95	6.30
FLS9-ZF18 2	32	4.13	5.19	6.37	7.69	9.18	10.85	12.70	4.16	4.30	4.51	4.79	5.12	5.50	5.92
	38	3.83	4.80	5.86	7.05	8.37	9.86	11.50	4.55	4.70	4.92	5.20	5.53	5.92	6.35
	43	3.57	4.46	5.42	6.49	7.67	9.01	10.50	4.90	5.05	5.28	5.57	5.91	6.30	6.75
	46	3.41	4.25	5.15	6.14	7.24	8.48	9.87	5.12	5.28	5.51	5.80	6.15	6.55	6.99
	49	3.25	4.03			6.80	7.94	9.23	5.35	5.52			6.40	6.80	7.25

Note:

1. Operating conditions: 20°C suction gas return temperature and 0K sub cooling
2. Stated power values are inclusive of fan power

Medium temperature single fan model

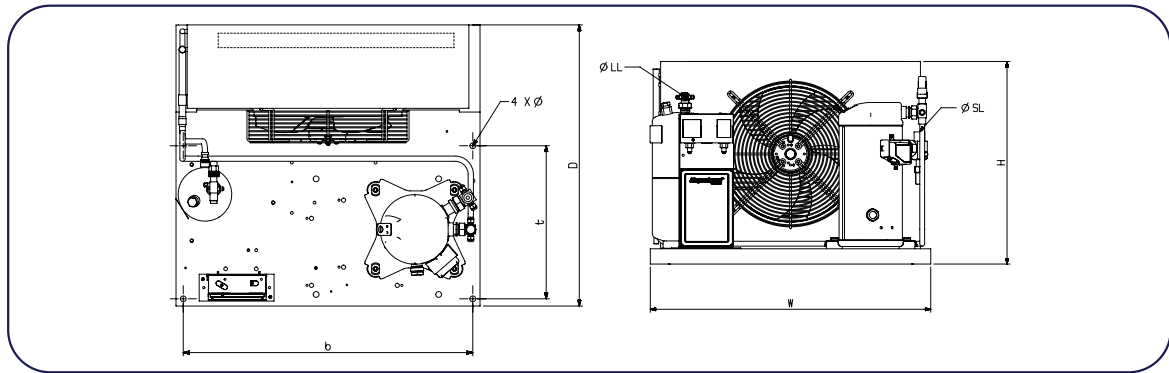

Medium temperature double fan model

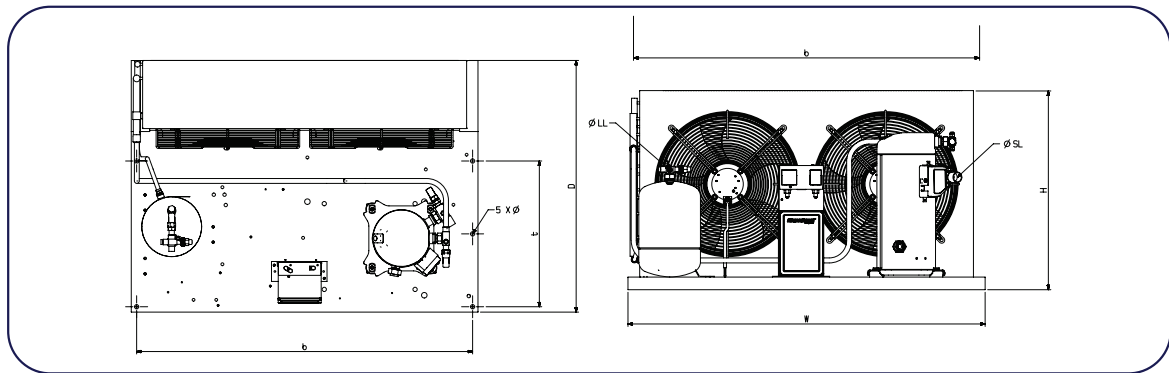

Low temperature single fan model

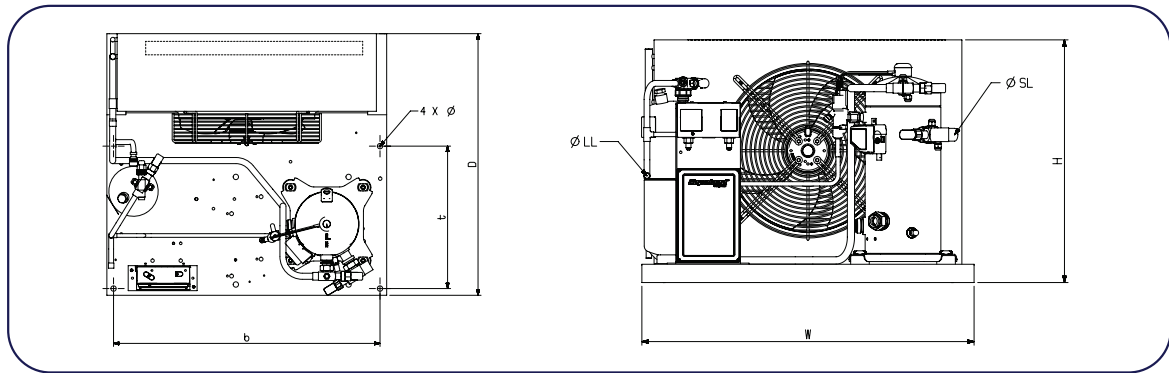

Low temperature double fan model

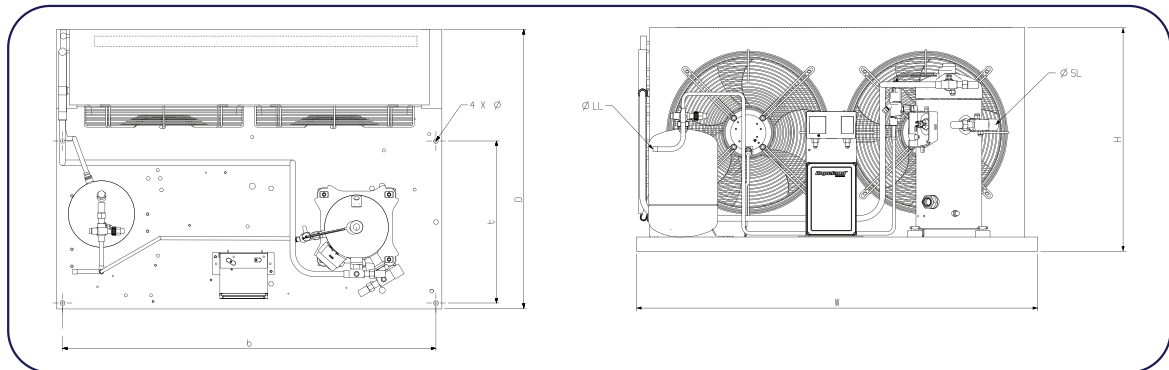

Model	Receiver capacity (l)	Air flow (m ³ /s)	Depth/width [D/W] (mm)	Height [H] (mm)	Base mounting Ø [b/t] (mm)	Suction Ø [SL] (")	Liquid Ø [LL] (")	Net weight (kg)	Gross weight (kg)
FMH8-ZB15	7.9	1.00	680/735	531	700 x 370 (14)	3/4	1/2	64	79
FMM8-ZB19	7.9	0.92	730/735	708	700 x 390 (14)	7/8	1/2	74	91
FMM8-ZB21	7.9	0.92	730/735	708	700 x 390 (14)	7/8	1/2	74	91
FMR6-ZB26	7.9	1.41	820/1130	630	1095 x 475 (14)	7/8	1/2	95	135
FMR7-ZB29	7.9	1.97	820/1130	630	1095 x 475 (14)	1 1/8	1/2	99	139
FMS9-ZB38	11.7	1.94	820/1130	706	1095 x 475 (14)	1 1/8	5/8	115	155
FMV9-ZB45	11.7	2.18	820/1330	832	1295 x 475 (14)	1 1/8	5/8	128	208
FMV9-ZB48	15.8	2.18	820/1330	832	1295 x 475 (14)	1 1/8	3/4	129	209
FMV6-ZB57	15.8	2.97	820/1330	832	1295 x 475 (14)	1 1/8	3/4	147	227
FMV6-ZB66	15.8	2.97	820/1330	832	1295 x 475 (14)	1 3/8	3/4	166	246
FLH8-ZF06	3.9	1.00	680/735	531	700 x 370 (14)	3/4	1/2	67	82
FLM8-ZF09	7.9	0.92	730/735	708	700 x 390 (14)	3/4	1/2	76	93
FLR6-ZF11	7.9	1.41	820/1130	630	1095 x 475 (14)	7/8	1/2	95	135
FLR7-ZF13	7.9	1.97	820/1130	630	1095 x 475 (14)	7/8	1/2	106	146
FLS9-ZF15	7.9	1.94	820/1130	706	1095 x 475 (14)	1 1/8	1/2	118	158
FLS9-ZF18	11.7	1.94	820/1130	706	1095 x 475 (14)	1 1/8	5/8	118	158

Condensing unit model	Compressor model	Compressor maximum operating current (A)	Compressor locked rotor current (A)	Condenser fan (qty x model)	Condenser fan current for each fan 230V/1/60Hz (A)
FMH8-ZB15-TF7	ZB15KQE-TF7-559	5.1	27	1 x 271	1.4
FMM8-ZB19-TF7	ZB19KQE-TF7-559	6.0	30	1 x 271	1.4
FMM8-ZB21-TF7	ZB21KQE-TF7-559	7.2	39	1 x 271	1.4
FMR6-ZB26-TF7	ZB26KQE-TF7-559	8.8	41	2 x 121	0.65
FMR7-ZB29-TF7	ZB29KQE-TF7-559	10.0	54	2 x 271	1.4
FMS9-ZB38-TF7	ZB38KQE-TF7-559	13.0	64	2 x 271	1.4
FMV9-ZB45-TF7	ZB45KQE-TF7-559	13.1	70	2 x 271	1.4
FMV9-ZB48-TF7	ZB48KQE-TF7-559	15.0	100	2 x 271	1.4
FMV6-ZB57-TF7	ZB57KQE-TF7-559	19.4	119	2 x 611	2.25
FMV6-ZB66-TF7	ZB66KQE-TF7-551	21.2	140	2 x 611	2.25
FMH8-ZB15-TFC	ZB15KQE-TF5-559	10.2	55	1 x 271	1.4
FMM8-ZB19-TFC	ZB19KQE-TF5-559	12.9	63	1 x 271	1.4
FMM8-ZB21-TFC	ZB21KQE-TF5-559	14.3	77	1 x 271	1.4
FMR6-ZB26-TFC	ZB26KQE-TF5-559	17.7	88	2 x 121	0.65
FMR7-ZB29-TFC	ZB29KQE-TF5-559	18.5	91	2 x 271	1.4
FMS9-ZB38-TFC	ZB38KQE-TF5-559	22.4	128	2 x 271	1.4
FMV9-ZB45-TFC	ZB45KQE-TF5-559	26.0	156	2 x 271	1.4
FMV9-ZB48-TFC	ZB48KQE-TF5-559	25.2	164	2 x 271	1.4
FMV6-ZB57-TFC	ZB57KQE-TF5-559	32.1	224	2 x 611	2.25
FMV6-ZB66-TFC	ZB66KQE-TF5-551	40.3	225	2 x 611	2.25
FLH8-ZF06-CFV	ZF06KQE-PFV-551	17.1	61	1 x 271	1.4
FLM8-ZF09-CFV	ZF09KQE-PFV-551	20.2	88	1 x 271	1.4
FLR6-ZF11-CFV	ZF11KQE-PFV-551	24.7	109	2 x 121	0.65
FLR7-ZF13-TF7	ZF13KQE-TF7-551	10.0	57	2 x 271	1.4
FLS9-ZF15-TF7	ZF15KQE-TF7-551	12.0	64	2 x 271	1.4
FLS9-ZF18-TF7	ZF18KQE-TF7-551	14.0	70	2 x 271	1.4
FLH8-ZF06-TFC	ZF06KQE-TF5-551	10.0	55	1 x 271	1.4
FLM8-ZF09-TFC	ZF09KQE-TF5-551	13.0	77	1 x 271	1.4
FLR6-ZF11-TFC	ZF11KQE-TF5-551	14.5	88	2 x 121	0.65
FLR7-ZF13-TFC	ZF13KQE-TFC-551	16.0	99	2 x 271	1.4
FLS9-ZF15-TFC	ZF15KQE-TFC-551	22.0	123	2 x 271	1.4
FLS9-ZF18-TFC	ZF18KQE-TFC-551	25.0	156	2 x 271	1.4



About Copeland

Copeland, a global provider of sustainable climate solutions, combines category-leading brands in compression, controls, software and monitoring for heating, cooling and refrigeration. With best-in-class engineering and design and the broadest portfolio of modulated solutions, we're not just setting the standard for compressor leadership; we're pioneering its evolution. Combining our technology with our smart energy management solutions, we can regulate, track and optimize conditions to help protect temperature-sensitive goods over land and sea, while delivering comfort in any space. Through energy-efficient products, regulation-ready solutions and expertise, we're revolutionizing the next generation of climate technology for the better.

To learn more, visit copeland.com

(10/23) Copeland F-Series scroll condensing units - 60Hz

©2024 Copeland LP.

COPELAND